

INSTRUCTION MANUAL

Vacuum Control Type
PARECT Electro-pneumatic
Regulator

EV2100 V· EV2109V

- Please read this instruction manual carefully before using this product, particularly the section describing safety.
- Retain this instruction manual with the product for further consultation whenever necessary.

For Safety Use

To use this product safely, basic knowledge of pneumatic equipment, including materials, piping, electrical system and mechanism, is required (to the level pursuant to JIS B 8370 Pneumatic System Rules).

We do not bear any responsibility for accidents caused by any person without such knowledge or arising from improper operation.

Our customers use this product for a very wide range of applications, and we cannot keep track of all of them. Depending on operating conditions, the product may fail to operate to maximum performance, or cause an accident. Thus, before placing an order, examine whether the product meets your application, requirements, and how to use it.

This product incorporates many functions and mechanisms to ensure safety. However, improper operation could result in an accident. To prevent such accidents, read this instruction manual carefully for proper operation.

INDEX

EV2100V · EV2109V
Vacuum Control Type PARECT Electro-pneumatic
Regulator
Manual No. SM-274995-A

1. PRODUCTS	
1.1 Specifications	4
1.2 Dimensions	6
2. OPERATION	
2.1 Zero point and Span adjustment	7
3. INSTALLATION	
3.1 EV2100V series	8
3.2 EV2109V series	9
3.3 Vacuum block option	11
3.4 Wiring	12
4. HOW TO ORDER	14

NOTE: Letters & figures enclosed within Gothic style bracket (examples such as [C2-4PP07] · [V2-503-B] etc.) are editorial symbols being unrelated with contents of the book.

⚠ WARNING a) If the product remains connected to its supply vacuum pressure for a long time while leaving the power turned off, the output vacuum pressure may increase to the level of the supply vacuum pressure. For safety, when there is a problem, use the valve on either the inlet or outlet side. It is recommended to set up the system for safe operation.

⚠ CAUTION a) The media used for working should be filtered compressed dry air devoid of any solid material, moisture and tar.

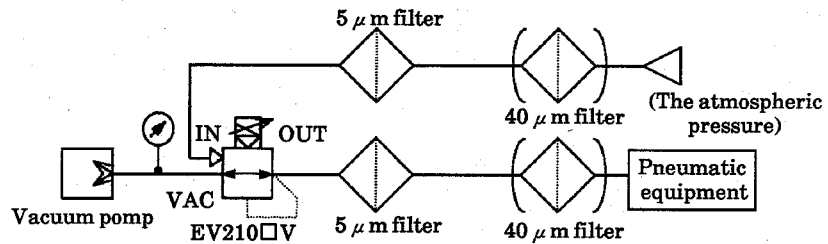

<Recommended air circuit>

- b) The products response capability will be affected by the working vacuum pressure and load volume. When a stable response is required, regulate the working vacuum pressure.
- c) To avoid malfunction caused by electrical noise:
 - Insert a line filter into the AC power line.
 - Use a surge suppresser like a CR or diode in the inductive load (solenoid valve, relay and so on) to remove any noise at the source.
 - Keep the EV series cables as far away as possible from power line for motor.
 - Use optional shielded cable connector for the wiring to the PARECT electro-pneumatic regulator, or compatible connectors (cable socket) and shielded wire.
- d) If the power is turned off when the unit is up to control vacuum pressure, the pressure will be maintained. In this case, if you need to be in an atmosphere release, lower the control vacuum pressure first and then turn off the power or use the exhaust valve. However, the maintained pressure is not guaranteed to last for very long.
- e) Since the working vacuum pressure is supposed to provide the exact control pressure, set it within the working vacuum pressure range. Especially, the follow conditions have adverse effect on the product life.

The vacuum pressure control is set from the working vacuum pressure till + 12%F.S. and the working vacuum pressure is instability.

- ⚠ CAUTION** f) When the output side control vacuum pressure is used with the air atmosphere open, pressure fluctuations may occur depending on the piping conditions and the inhalation conditions.
Though it requires some trouble, please either verify via testing using the actual use conditions or consult this firm.
- g) Please note that residual vacuum pressure of -5kPa or lower will be generated when the input signal is the minimum.
- h) It is possible for the input signal current type to put into 1 to 5VDC instead of 4 to 20mADC. Please use the signal generator which is able to output 20mADC or more.
- i) Select only the vacuum pump, vacuum filter, and regulator having the flow rate higher than that used for PARECT units.

About mounting, installation and adjustment

- ⚠ CAUTION** a) Avoid operating the product in places where it may be affected by direct sunlight, water or oil.
- b) When applying a seal tape, start from a position 2-mm or more away from the end of the thread portion on the tube, to a direction opposite to the tip of the tube, and wind the tape around the tube in a direction reverse to the direction of the thread.
- *If a part of the seal tape is positioned closer to the tip of the tube than the thread portion, the tape may be threaded into pieces as the tube is screwed into the joint; they may go into the tube and cause trouble.

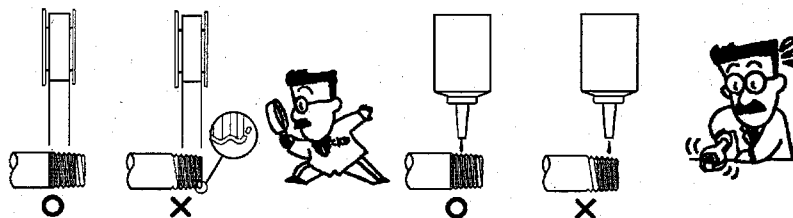

**CAUTION**

- d) When succeed to the plumbing port (VAC,OUT,IN)and attach the hand leakage without please pay attention so that the limit powder of the seal material and plumbing screw do not penetrate inside by using the seal material, as.
Also, VAC port of I succeed and as for the tightening of the hand please do and please do spanner credit in the vacuum block(□27)
- e) Since proper pressure control is not possible if the IN port is plugged, always keep the air open.
- f) In the case that it connected several units with module connection about EV2109Vseries the atmosphere release port(IN1,IN2) becomes common.
- g) The optional shielded cable connector is of a shielded 4-core wire type.
If you are not going to use the green wire for special use (refer to 4-4 the wiring procedure), be careful not to allow the cable to contact other cables (including the shielded wire).

About use and maintenance**CAUTION**

- a) Avoid dismantling the product as this will cause damage.

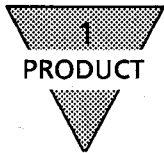

1. PRODUCT

1.1 Specifications

Model		EV2100V		EV2109V	
Item					
Media		Cleaned air			
Working vacuum pressure range		-96kPa to -101.3kPa			
Guaranteed pressure proof	Vacuum side	196kPa			
	Outlet side	196kPa			
Vacuum control range		0 to -101.3kPa			
Vacuum accuracy guarantee range		-10.1 to -91.2kPa			
Power supply voltage		DC24V \pm 10% (Stabilized power supply with a ripple rate of 1% or less)			
Consumption current		0.1A or less (Rush current : 0.6A when the power is turned on)			
Input signal (Input impedance)		0 to 10V DC (20k Ω)	0 to 5V DC (10k Ω)	4 to 20mA DC 1 to 5V DC (250 Ω)	10k Ω variable resistor or (10k Ω)
Monitor output		1 to 5V DC (However, there is no monitor output when the 10k Ω variable resistor is input)			
Connection procedure		Shielding cable connector, compatible connector or shielded wire.			
Insulation resistance		100 M Ω (DC 500 V) or more			
Withstand voltage		AC 1500 V 1 minute			
Accuracy ※1	Hysteresis	1%F.S. or less			
	Linearity	\pm 0.5%F.S. or less			
	Resolution	0.5%F.S. or less			
	Repeatability	0.5%F.S. or less			
Temperature characteristics	Zero point fluctuation	0.15%F.S./ $^{\circ}$ C or less			
	Span fluctuation	0.07%F.S./ $^{\circ}$ C or less			
Max. flow rate (ANR) ※2		150 ℓ /min (ANR)		120 ℓ /min (ANR)	
Step response ※3	No load	0.6 s or less			
	1 ℓ load	2.0s or less			
Air leak from the por	OUT port ※4	10cm ³ /min(ANR) or less			
	IN port ※5	100cm ³ /min(ANR) or less			
Air leak to the outside ※6		1cm ³ /min(ANR) or less			
Withstanding vibration		98m/s ² or less (JISC0040)			
Working temperature range		5 to 50 $^{\circ}$ C			
Fluid temperature		5 to 50 $^{\circ}$ C			
Preserving temperature range		-10 to 67 $^{\circ}$ C			
Working humidity range		45 to 85%RH (no dewdrop)			
Preserving humidity range		96%RH or less			
Lubrication		Nil			
Mounting position		Free			
Protection structure		Equivalent to IP 64 (body), IP 67 (cable connector)			
Port size		Rc 1/4			
Mass (body)		300g		320g	

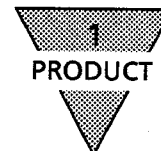

- ※1 This specifications are when the power supply voltage is just 24VDC.
- ※2 Working vacuum pressure : -100kPa
- ※3 Working vacuum pressure : -100kPa, Step rate :: 50%F.S. → 90%F.S.
 50%F.S. → 60%F.S.
 50%F.S. → 40%F.S.
- ※4 Working vacuum pressure : -100kPa,
On condition that the power supply voltage (DC24V) and the input signal is turned off.
- ※5 Working vacuum pressure : -100kPa,
On condition that the power supply voltage(DC24V) and 10% of input signals is on.
- ※6 This is the air leak to the outside except "VAC", "OUT" and "IN" port.
On condition that -100kPa is applied to "VAC", "OUT" and "IN" port.



1.2 Dimensions

• EV2100V

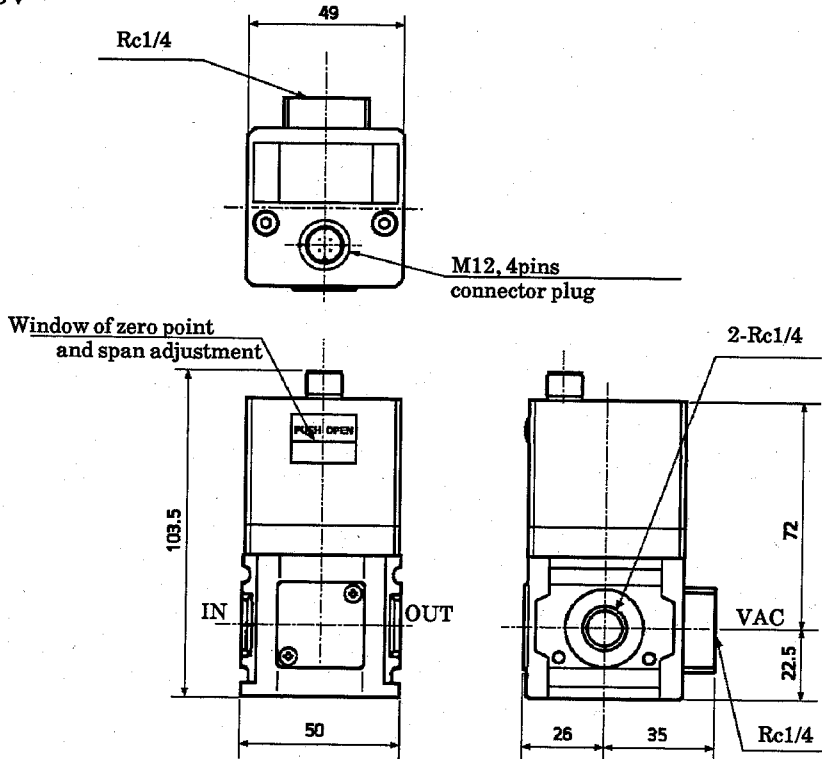

• EV2109V

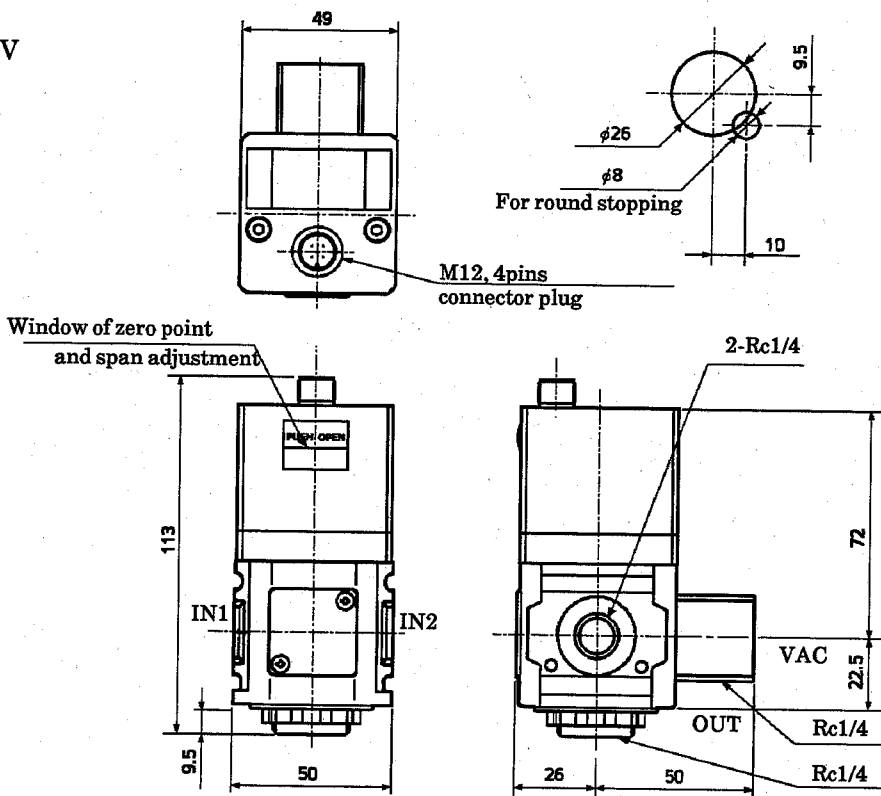

2. OPERATION

2.1 Zero point and Span adjustment

The product is adjusted, when it is charged at the factory, to output the specified control pressure range in response to each input signal. If more adjustment is required, it will be done with the trimmer inside the adjustment window by using a small “-” screwdriver, like a precision driver.

These adjustments are extremely sensitive. Since even the slightest trimmer operation will cause a large fluctuation in the output pressure, carry out these adjustments with care.

For the opening and closing of the adjustment window, refer to fig. 1 “How to open and close the adjustment window”.

[How to open the adjustment window]

Press the “PUSH OPEN” part as indicated by the arrow ①, to enable the part under the window to pop out. Then pull this part toward you as indicated by the arrow ②. In this way, the window will come off.

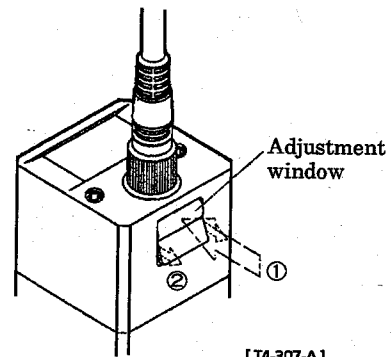

[T4-307-A]

Fig1 How to open and close the adjustment window.

[How to close the adjustment window]

Push the window through the frame.

The Zero point and Span adjustment should be performed with the zero point adjustment trimmer and span point adjustment trimmer, inside the adjustment window as shown in fig. 2. For the trimmer, an endless trimmer of three revolutions is used.

※ Adjust the zero and span points to achieve the required values while confirming the input signal and output pressure. Adjust the zero point first.

※ Zero point ... The control pressure value when the input signal is zero.

Span point ... Generally the span means the range is from the max. control pressure value to the min. control pressure value.

Non the span point means 90% of the max. control pressure value.

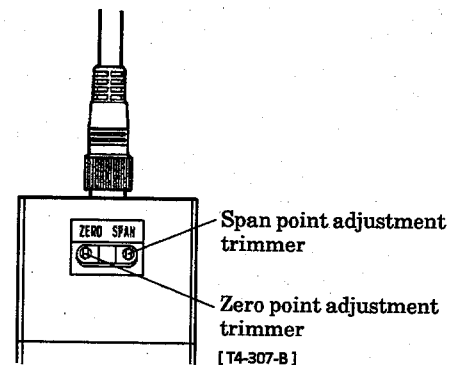

[T4-307-B]

Fig2 Zero point and Span adjustment trimmers

3. INSTALLATION

There are no restrictions on the installation position of the EV series, but as a principle, it should be installed upright with its resin cover facing upward (housing), and further, should be installed the position that can easily be adjusted (Zero/span adjustment).

3.1 EV2100V series (Single type)

1) Installation with brackets

(1) Floor installation type

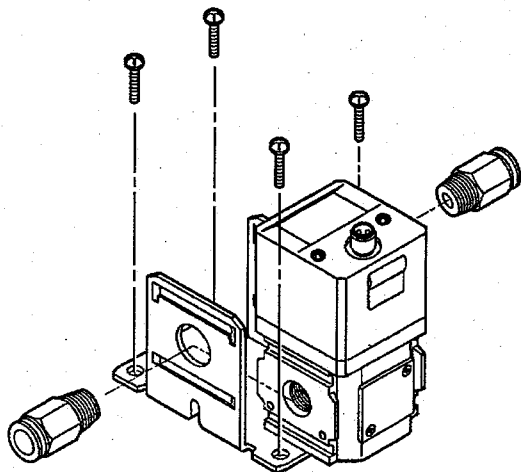
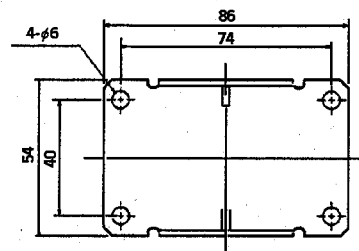

Fig. 3 Installation with Type B bracket. [4-407-A]



[T4-407-B]

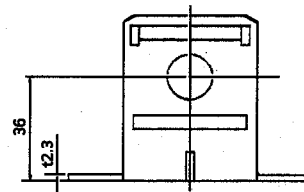

Fig. 4 Type B bracket dimensions

2) Installation with joiners (Only for the wall installation)

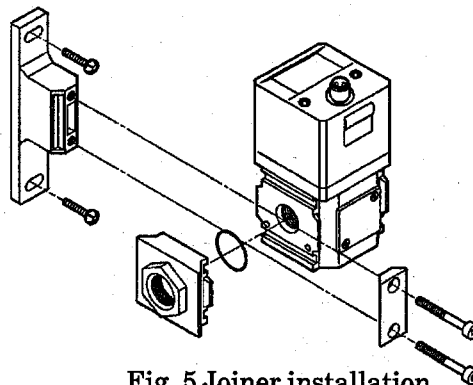

Fig. 5 Joiner installation

With the use of joiners, the EV series can be connected with the C3000, C4000 series and also with other peripheral equipments, that will eliminate troublesome pipe installation work. In addition, it will improve ease of installation as well as its designing and maintainability. (Refer to fig. 7 "Upgrading the System with Joiners")

3.2 EV2109V series (Manifold type)

1) Installation with a bracket (Only for the wall installation)

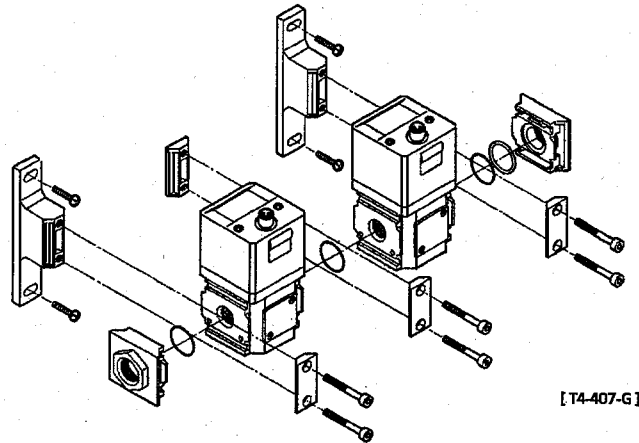

Fig. 6 Installation with type C bracket

The use of joiners will save space even when using more than one EV series of the same type.

A system upgrade example

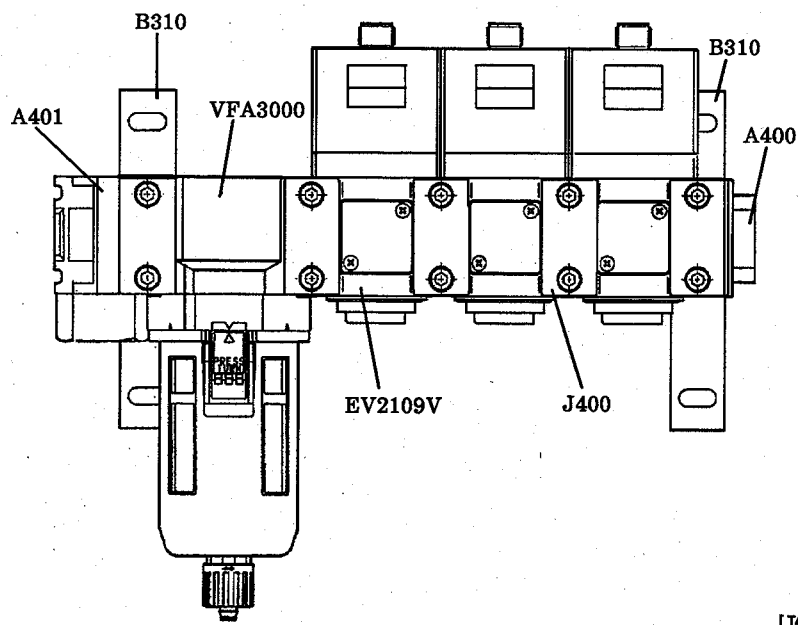

Fig. 7 The example of system upgrade with joiners

Refer to our catalog "Selex F.R.L." for peripheral equipment for upgrading the system or contact us.

2) Panel mounting

A manifold type accepts panel mounting.

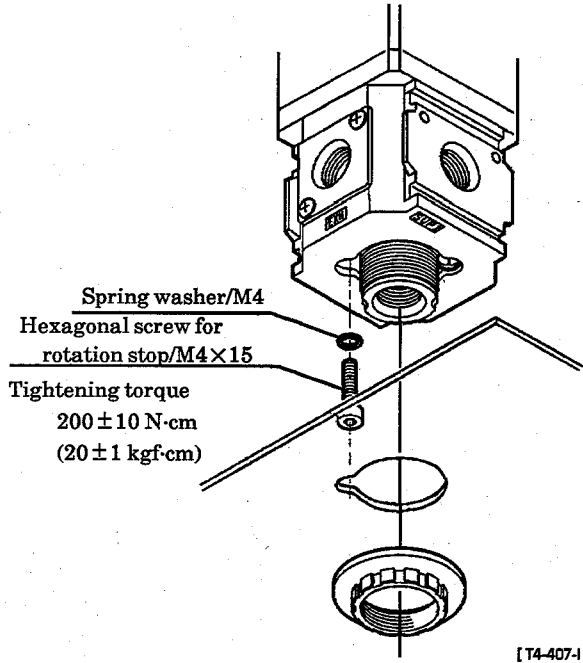

Fig. 8 Panel mounting

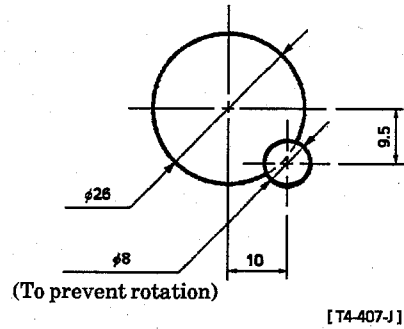

Fig. 9 Panel cutting

Select a panel 3.2 mm or less in thickness and drill the mounting points as indicated in the fig. 9 for Panel cutting.

If the prevention of itself rotation is necessary for the body, replace one of the two Cross-recessed head tapping screws for the panel mounting face with the specified hexagon socket head cap screw and fit it to the specified tightening torque.

However, when using a screw to prevent rotation use a panel 0.8 -3.2 mm in thickness. (If a panel 1.6 mm or less in thickness is used, remove the spring washer that is attached to the screw)

3.3 Vacuum block Option

EV2100V, EV2109V series has 2 different types of vacuum block option.
Choose one according to your application.

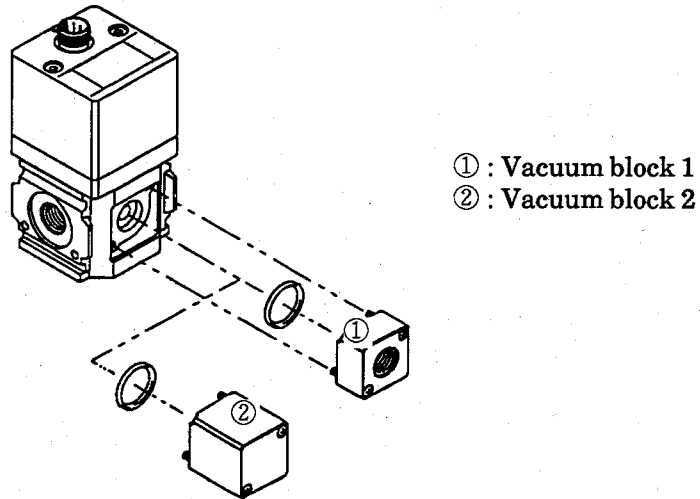

Fig. 10 Vacuum block options

The screw tightening torque should be $75\text{N} \cdot \text{cm}$ following and do spanner credit in the vacuum block (□ 27)

3.4 Wiring

Use the specified (optional) shielded cable connector for connecting to the body.
 (If you are not going to use the specified cable connector, the following cable sockets are recommended. However, a shielded wire is required for the cable.)

- Screw lock type : ELWIK4012 C. CORRENS & CO. ltd.
- Soldering type : Type XS2C-D422 OMRON ltd.

Connection procedure

How to connect the cable connector to the body is shown in fig. 11.

Align the notches of the connector terminal with the SYMBOL Δ "Symbol" mark on the body terminal. Insert the connector.

Turn the inner screw locking ring in the direction of ① until you hear a click.

After confirming that the connector has been fixed, turn the inner screw locking ring in the direction of ② and then screw firmly.

(Cautions)

- If you do not turn the inner screw lock ring in the direction of ①, it may cause a problem in screw alignment resulting in damaging the body screw threads. Be sure to follow the above procedure.
- If you turn the inner screw locking ring too much, for example by using a tool, it may damage the body connector. Be sure to turn the ring manually.

Connection procedure

The connection procedure differs depending on the voltage input type, current input type and variable resistor type. Be sure to check the product model. before performing connection work.

As shown in fig. 12 "Connection procedure for individual types", Connect with the power supply and signal sources in accordance with each input signal form.

If you are not going to perform monitor-output with the voltage input type and current input, be sure to avoid contacting the cable with other cables (including the shielded wire).

The shielded wire should be grounded on the power supply side.
 Also, do not forget to take the steps to avoid noise, outlined in "CAUTION."

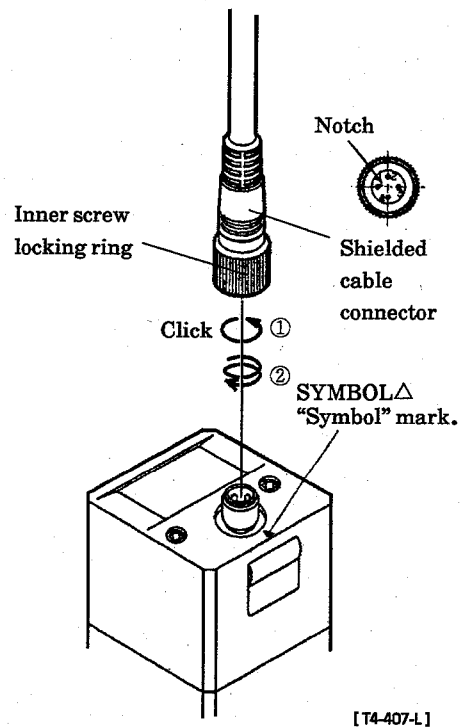
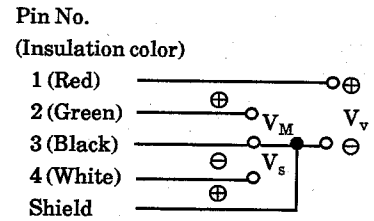
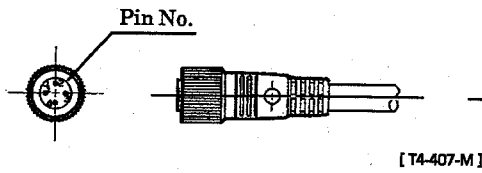
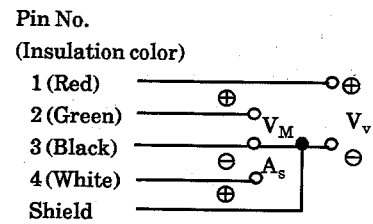
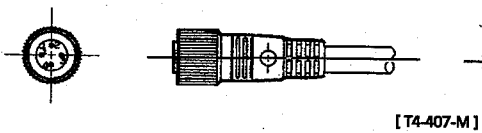

Fig. 11 Connection procedure

Voltage input type



Current input type



Variable resistor type

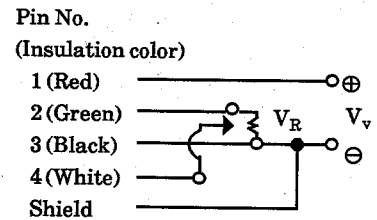
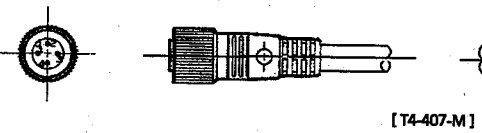

- V_V : Power supply voltage/24 VDC
- V_S : Voltage signal/0-5, 0-10 VDC
- A_S : Current signal/4-20 mA
- V_M : Monitor output signal/1-5 VDC
- V_R : Variable resistor/10 K Ω

Fig. 12 Connection procedure for individual types.

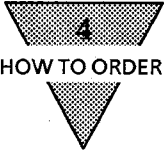

4. HOW TO ORDER

E V 210 (a) V - (b) (c) - (d)

㉓ Body type		㉔ Input signal	
0	Single unit	0	0-10V DC
9	Single unit for manifold	1	0-5V DC
		2	4-20mA DC or 1-5V DC
		3	10kΩ variable resistor or 0-10V DC

㉕ Port size		㉖ Option ※					
08	Rc1/4	Optional cable		Optional vacuum block		Optional bracket	
		No code	Non	No code	Vacuum block 1	No code	Non
		C11	1m attached	K1	Vacuum block 2	B4	B type bracket attached
		C13	3m attached			T	T type bracket attached

※ EV 2000 - (option symbol) should be applied only for optional parts.

※ Optioal vacuum block of "Vacuum block1" and the optional bracket of "T type bracket" of the combination are not able to select.